



**TRUE REFRIGERATION
INTERNATIONAL**

UK Tel +44 (0) 1709 888 080 • Germany Tel +49 (0) 7622 6883 0
Free Phone to U.S. 0 800 894 928 • www.truemfg.com



5/20

Model:
TUC-27F-LP-HC

Undercounter:
Low Profile Solid Door Freezer with Hydrocarbon Refrigerant



TUC-27F-LP-HC

- ▶ True's undercounter's are designed with enduring quality and value that protects your long term investment. Our commitment to using the highest quality materials and oversized refrigeration ensures exceptional food preservation.
- ▶ "Low Profile" models are designed to slide easily under custom built countertops.
- ▶ 1 1/2" (39 mm) diameter dual swivel castors. 31 7/8" (810 mm) work surface height.
- ▶ Factory engineered, self-contained, capillary tube system using environmentally friendly R290 hydro carbon refrigerant that has zero (0) ozone depletion potential (ODP), & three (3) global warming potential (GWP).
- ▶ Oversized, factory balanced, refrigeration system holds -10°F (-23.3°C). Ideal for frozen food and ice cream.
- ▶ Stainless steel front, countertop, and sides. Corrosion resistant GalFan coated steel back.
- ▶ Interior - attractive, NSF approved, clear coated aluminum liner with stainless steel floor.
- ▶ Self closing door. Positive seal, torsion type closure system.
- ▶ Foamed-in-place using a high density, polyurethane insulation that has zero ozone depletion potential (ODP) and zero global warming potential (GWP).

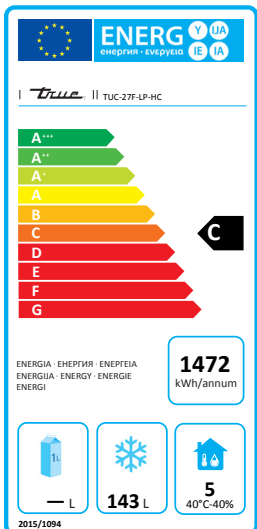

PLAN VIEW

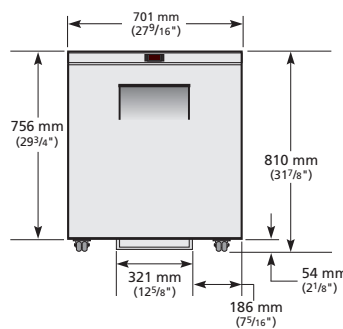

ELEVATION

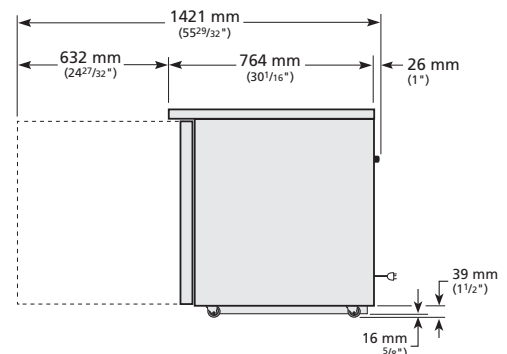

RIGHT VIEW

ROUGH-IN DATA

Voltage: 220-240V/50-60Hz

Specifications subject to change without notice.
Chart dimensions rounded up to the next whole millimeter (inches rounded up to the next 1/8").

Model	Model Type	Doors	Shelves	Cabinet Dimensions (mm)			Net Volume (litres)	EEC	EEI	24 hr/ Energy Consumption (kWh)	Annual Energy Consumption (kWh)	Crated Weight (kg)
				W	D	H						
TUC-27F-LP-HC	Counter Frozen	1	2	702	766	810	143	C	45.8	4.034	1472	91

† Depth does not include 26 mm for rear bumpers.